

USER MANUAL		
WEIGHT LOADED SAFETY VALVES ZARMAK	570	Edition: 1/2025 Date: 20.02.2025

TABLE OF CONTENTS

1. Principle of operation
2. Delivery condition
3. Installation of safety valves
4. Operation of safety valves
5. Adjustment of the set pressure
6. Replacing the gasket between the body and the bonnet
7. Replacing the gasket between the bonnet and the cap
8. Replacing the valve disc
9. Valve type with locking screw (test gag)
10. Spare parts list
11. Maintenance and repair of safety valves
12. Operating disturbances and their elimination
13. Valve service discontinuity
14. Warranty



Figure 570

1. Principle of operation

The purpose of the safety valve is to protect the equipment and installation against excessive pressure above the pressure limit. When the force coming from the pressure acting on the disc surmount with the weight of the working elements, the valve starts to open. A further increase in the pressure, required for the particular design of the valve, causes its full opening aided by the bell (fig. 3 pos. 4).

2. Delivery condition

Supplied valves are tested and set for the required opening pressure. Valves are stamped on a nameplate fixed to the body and with the of signs on the edge of the outlet flange.

Nameplate

For valve 570

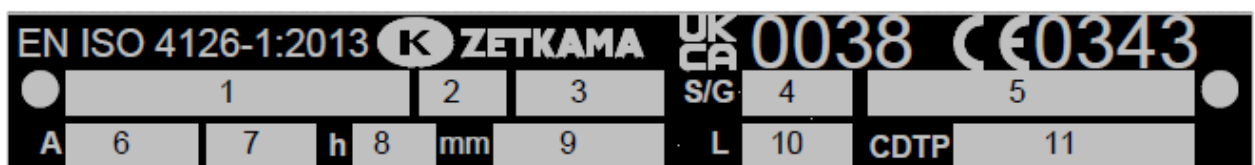

Symbols:

1 Type of safety valve

2. Bore diameter
3. Spring number
4. The discharge coefficient for vapours and gases
5. Set pressure or set pressure range
6. Flow area
7. For new valves: Year of production
For valves serviced directly by ZETKAMA: Year of conducting service / S
For valves serviced by an authorized service technician: Service technician's letter identifier / year of conducting service
8. The minimum lift value
9. Overpressure
10. The discharge coefficient for liquids
11. Cold Differential Test Pressure

Additionally, the outlet flange is marked with:

1. Year of manufacture / serial number
2. Workstation number of assembler
3. Stamp of an operator performing the test

Set pressure is secured by sealing between the cap and bonnet. In order to secure the valve during transport, the lever is being attached to the outlet flange with a wire, and the flow holes are being plugged. For transportation the spindle is secured with a blocking screw, fastened with a metal strip. The external surfaces of the valve are painted.

3. Installation of safety valves

- Before the installation on the unit or pipeline, remove the fastening tape, take out the blocking screw, unscrew the plug and check if valve was not damaged or contaminated during transport. It is absolutely necessary to check the cleanliness of flow channels, external surfaces and end connections. Surfaces of flanges should be cleaned of preservative and of any possible impurities.



To lift safety valves rope should be used on the body and bonnet in accordance with drawing. 1. Do not lift the valve at the lifting lever



The valve should be mounted in a vertical position.

- After installing the valve, loosen the lever by removing the wire.
- Pipes connected to the valve should comply with the requirements included in the surveillance provisions. Cross-section and shape of the pipes should be selected so that they do not reduce the capacity of the valve. If the medium is discharged with one pipeline from a few safety valves, free area of the flow of this pipeline should be at least equal to the total area of outlet ports flow of these valves. Moreover, the pipes should be made advantageously to the flow (gentle curves). For valves equipped with drainhole condensate drainage should be used. For valves that do not have drainhole, drain should be provided at the lowest point of the discharge pipe.
- Full-lift safety valves from the range of PN 40 from DN 40 has a cast support lugs at the body, used with appropriate mounting to take the reaction forces over by the outlet.
- In order to avoid reaction forces at the outlet connection of the valve, it is required to use an appropriate support to the pipeline.
- The valve cannot act like a support structure for the pressure equipment on which it is mounted, and it cannot be exposed to deformation caused by installation of inlet and outlet pipes. When mounting the

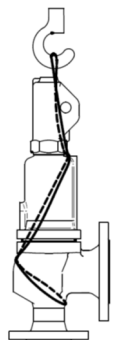

Drawing 1

valve flange with the flange of the pressure equipment, use the appropriate gasket (adapted to the type of valve face and with respect to parameters and medium type).

- Flange bolts should be tightened evenly and with crisscross pattern. They should also be tightened after a certain period of operation of the valve or in the event of a leak.
- Mounting place of the valve should be easily accessible, good lighted and protected from external influences. If the safety valve is mounted outdoors, it must be protected against frost and rain. When mounted near the platforms for service, they must be in compliance with the provisions of Health and Safety Regulations (blowing valve should not be a threat to the health and life of people).

4. Operation of safety valves

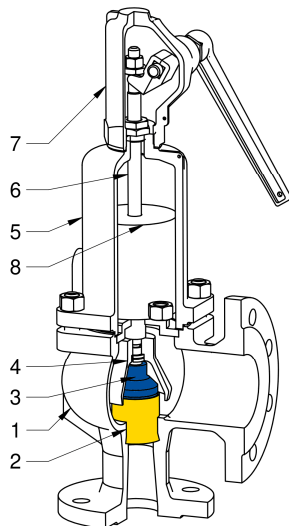

1	Body	2	Seat/Inlet nozzle	3	Disc	4	Bell
5	Bonnet	6	Stem	7	Cap	8	Weight

Drawing 2

Safety valves that serve as important elements of the devices and pressure systems require particularly careful and competent service. Any operational gasp may cause damage to the valve mechanism, and consequently lead to the total failure of the pressure system. Therefore, during the operation, pay special attention to:

- proper setting of safety valve, suitable for the operating parameters of the equipment being protected,
- proper protection of the valve mechanism against possibility of damage,
- periodically verification of correct operation of the valve, in accordance with the requirements of surveillance,
- proper maintenance and repair management.

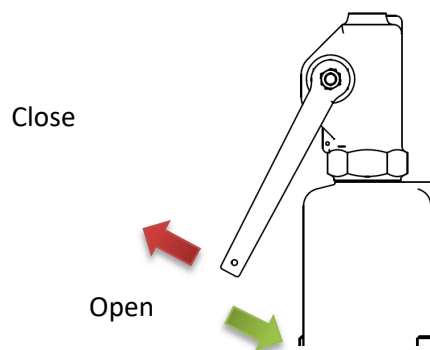

Drawing 3

Checking the safety valve operation involves lifting of the disc with a lever, running it in the direction indicated in Drawing 3. Starting the lever causes minimum lift of the disc and the flow of medium. Keep in mind that too frequent checking may result in damage to the sealing surfaces of the valve disc and seat and thus to a loss of tightness, and the complete lack of checking usually leads to “seizing” of the valve mechanism, what can have serious consequences.

The frequency of these activities depends primarily on:

- Working condition, i.e. the type of medium flowing and its parameters,
- The specifics of the technological process,
- Place of installation,
- environment.

It should also be correlated with the test and repair of pressure equipment / installations that protects the valve. Very important is the experience of the user. Determining the periods of checking the safety valve is the responsibility of the designer of installation.

⚠ After checking of the valve, move the lever to the original position.

When checking the valve there is a possibility of contamination the sealing surfaces. In this case, again lift disc to remove these pollutions. If tightness was not obtained by this, the valve needs to be regrinded from the next stop of the pressure device.

⚠ Safety valve are not designed to use as a discharge valve, and inappropriate use dismiss producer from any obligation and warranty.

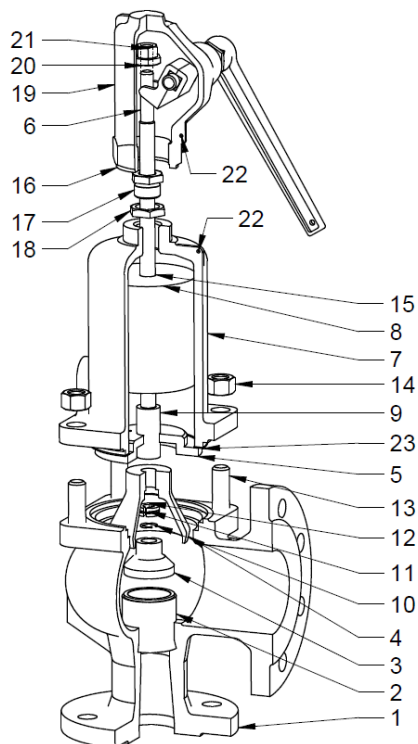

Drawing 4

5. Adjustment of the set pressure

Weight loaded valves do not have any elements allowing their regulation. It is recommended to send the valve to the producer for adjustment.

6. Replacing the gasket between the body and the bonnet



To replace the gasket, the security seal (22) between the body and the bonnet must be removed, which will void the warranty. In the case of valves covered by warranty, these activities must be performed by the manufacturer or a person designated by it or an institution with appropriate authorizations.

Replacing the gasket (23) should be carried out in accordance with the rules presented below:

1. Remove the security seal between the cap assembly (19) and bonnet (7)
2. Raise the handle as far as it will go in the "Close" direction (see drawing 3)
3. Unscrew the cap assembly (19)
4. Loosen the lock nut (18)
5. Unscrew the locking screw (17)
6. Unscrew the nuts (14) that secure the cap (7) to the body (1). In case of stud bolts (13) of the same length, unscrew the nuts (14) evenly alternately. In case of stud bolts (13) of different lengths, first unscrew the nuts (14) from the shorter bolts, and then unscrew the nuts from the longer bolts evenly alternately.
7. Dismantle the cap (7) and mark the location of the bolt hole in the cap with the corresponding stud bolt
8. Replace the gasket (23) between the body (1) and the cap (7) with a new one
9. Put the cap (7) on the stud bolts (13)
10. Screw on the nuts (14) that secure the body (1) to the cap (7). In case of studs (13) of the same length, the nuts (14) should be screwed in evenly alternately. In the case of studs (13) of different length, first screw in the nuts (14) on the longer studs evenly alternately, and then the nuts on the shorter studs.
11. Screw in the locking screw (17)
12. Lock the locknut (18)
13. Screw in the hood assembly (19), remembering to replace the gasket (16) with a new one

7. Replacing the gasket between the bonnet and the cap



To replace the gasket, the security seal (22) between the bonnet and the cap, which will void the warranty. In the case of valves covered by warranty, these activities must be performed by the manufacturer or a person designated by it or an institution with appropriate authorizations.

1. Remove the security seal between the cap assembly (19) and bonnet (7)
2. Raise the handle as far as it will go in the "Close" direction (see picture 4)
3. Unscrew the cap assembly (19)
4. Replace the gasket (16) with a new one
5. Screw on the cap assembly (19)

8. Replacing the valve disc



To replace the valve disc, the seal (22) between the bonnet and the cap, which will void the warranty. In the case of valves covered by warranty, these activities must be performed by the manufacturer or a person designated by it or an institution with appropriate authorizations.

1. Remove the security seal between the cap assembly (19) and bonnet (7)
2. Raise the handle as far as it will go in the "Close" direction (see picture 4)
3. Unscrew the cap assembly (19)
4. Loosen the lock nut (18)
5. Unscrew the locking screw (17)
6. Unscrew the nuts (14) securing the bonnet (7) to the body (1). In the case of stud bolts (13) of the same length, the nuts (14) should be unscrewed evenly and alternately. In the case of stud bolts (13) of different

heights, first unscrew the nuts (14) on the shorter bolts, and then unscrew the nuts on the longer bolts evenly, alternately.

7. Remove the bonnet (7) by marking the location of the screw hole in the cap with the corresponding stud bolt
8. Remove the weight (8) and the Seger ring (15) blocking it.
9. Holding the valve stem (6), pull out the entire valve closing system: insert (5), sleeve (9), bell (4), split ring (11) with spring ring (12), plug (3) with locking ring (10)
 - a) Dismantle the old plug (3) by pulling hard while holding the valve stem (6).
 - b) Install (if not pre-installed) a new locking ring (10) to the new plug
 - c) Press the new plug (3) onto the valve stem
10. Install the entire valve closing system
11. Install the weight (8) and secure it with the Circlip (15),
12. Replace the gasket (23) between the body (1) and the cap (7) with a new one
13. Place the cap (7) on the stud bolts (13)
14. Screw on the nuts (14) that secure the body (1) to the cap (7). In case of studs (13) of the same length, the nuts (14) should be screwed in evenly alternately. In the case of studs (13) of different length, first screw in the nuts (14) on the longer studs evenly alternately, and then the nuts on the shorter studs.
15. Screw in the locking screw (17)
16. Lock the locknut (18)
17. Assemble the cap assembly (19) don't forget about new gasket

9. Valve type with locking screw (test gag)

Applies to valve types: 240, 270, 600, 610, 613, 614, 630, 650, 670, 673, 674

Upon customer request, ZETKAMA safety valves can be supplied with a locking screw (test gag). These valves are factory-delivered with a screwed-in plug and a separately attached locking screw, along with a complete set of gaskets.

If the locking screw (test gag) needs to be used, follow these steps:

1. Unscrew the plug from the valve cap.
2. Remove the old gasket installed during the initial or last assembly.
3. Screw in the locking screw (no gasket is required).

To reinstall the protective plug:

1. Unscrew the locking screw (test gag) from the valve cap.
2. Install a new gasket provided with the factory-new valve.
3. Screw in the protective plug.

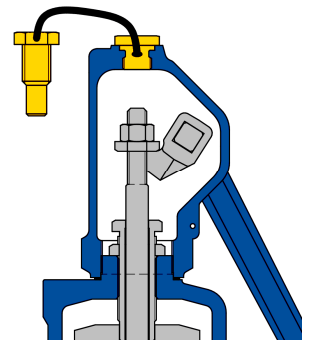

⚠ After completing the pressure test, the locking screw (test gag) must be removed. Failure to remove it will prevent the valve from operating in case of pressure buildup before the safety valve, which means the installation will not be protected.



For gas-tight valve types, it is essential to install a new gasket supplied or recommended by the manufacturer. The plug with the new gasket should be tightened to 30 Nm torque.

10. Spare parts list

Applies to valves 570

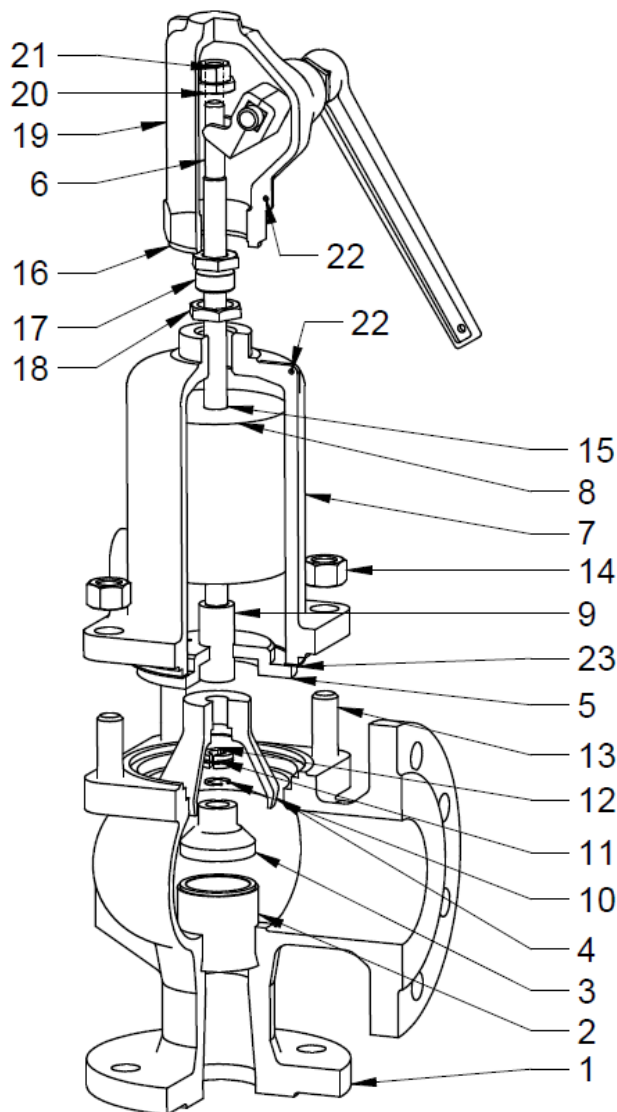

Repair kit 1

- 16 Seal between bonnet and cap
Acid-resistant gasket with graphite filling
- 23 Gasket between body and bonnet
Graphite gasket

Repair kit 2

- 3 Disc
- 10 Disc retaining ring
- 16 Seal between bonnet and cap
Acid-resistant gasket with graphite filling
- 23 Gasket between body and bonnet
Graphite gasket

Repair kit 3

- 3 Disc
- 4 Bell
- 6 Stem
- 10 Disc retaining ring
- 11 Split ring
- 12 Spring ring
- 16 Seal between bonnet and cap
Acid-resistant gasket with graphite filling
- 23 Gasket between body and bonnet
Graphite gasket

Repair kit 4

- 3 Disc
- 4 Bell
- 5 Insert
- 6 Stem
- 9 Sleeve
- 10 Disc retaining ring
- 11 Split ring
- 12 Spring ring
- 13 Stud bolts (pins)
- 14 Nut of stud bolts
- 15 Spring plates (Upper and lower)
- 16 Seal between bonnet and cap
Acid-resistant gasket with graphite filling
- 18 Lock nut
- 18 Adjusting screw
- 20 Stop nut
- 21 Stem nut
- 23 Gasket between body and bonnet
Graphite gasket

Weight (8)

For purchase it is necessary to specify the valve type, nominal diameter (DN) and valve setting pressure

Cap assembly (19)

When purchasing it is necessary to specify the valve type and its DN.

There is the option of buying a leverless cap and a cap with a sealed lever.

11. Maintenance and repair of safety valves

In order to ensure correct operation of safety valves, the following conditions must be met:

- valve disc cannot set slantwise to the valve seat;
- sealing surfaces of the seat and disc should ensure tight closure of the valve;
- all cooperating moving parts of valve mechanism should maintain movability in operating conditions.

In order to maintain these conditions the valves should be periodically inspected and renovated. Inspections of safety valves should be conducted by persons with adequate authorisation. However, repairs should be first carried by manufacturer of the safety valve or by authorised by it service providers, or by user repair teams with appropriate surveillance permissions.

ATTENTION

In addition to the recommendations included in these instructions, the requirements and recommendations resulting from the surveillance provisions of the country in which safety valve is operated also apply.

12. Operating disturbances and their elimination

Disturbance	Possible causes	Elimination
Safety valve does not work - no flow or slight flow	Protective cap of the inlet flange has not been removed prior to installation of the valve	Remove inlet flange protective cap.
	Mechanical components left in the system – they blocked the flow of the medium into the valve	Remove the valve from the system and clean inlet of the valve.
	incorrect installation of the valve - the flow of the medium is opposite with the direction marked on the valve body	Install the valve correctly, in accordance with the indications of manufacturer's instructions.
	Blocking screw is installed	Remove blocking screw and plug the hole in cap.
	backpressure not taken into consideration (in case of conventional valve, i.e. unbalanced)	For stable superimposed backpressure - set the differential pressure. For variable superimposed backpressure - apply bellows compensating backpressure changes In each case, follow manufacturer's instructions and with matters requiring clarification - consult the manufacturer's technical advisor.
	Freezing or solidifying medium	The body and the pipes should be kept in a state incapable freezing or solidifying of media - apply the heating.
"Seizing" of the sealing surfaces of the seat and valve disc preventing their separation at the set pressure	If the properties of the medium and the operating conditions do not exclude such possibility - appropriate frequency of inspections and repairs of the safety valve must be adapted, and the time of valve check provided in the operating records of protected device / system should be strictly observed.	

No repeatability of valve opening pressure (conventional valves, ie. unbalanced)	Variable superimposed backpressure	Replace conventional safety valve with the valve with bellows compensating superimposed backpressure changes.
	Blocking screw used for transport is not removed.	Remove the blocking screw
	Damages within the lever unit	Inspect the lever unit and when necessary replace damaged parts to new ones.
Leak at sealing surface	Incorrect transport or storage - wrong position during transport and storage, protective cap from the inlet and outlet of the valve have fallen out and thus the impurities entered into the valve	During transport and storage follow manufacturer's instructions. If the inner part of the valve has been polluted, it need to be cleaned before installing the valve in the system in order to avoid damage to the sealing surfaces.
	Working pressure is higher than 90% of set pressure. There is no corresponding relationship between the set pressure and the working pressure.	Working pressure has to be lower than 90% of set pressure. For correct pressures for safety valve use values recommended by manufacturer.
	Lever not in neutral position (in case of closed valves and low pressures)	Move the lever to the neutral position.
	Vibration of safety valve	Diagnose the cause of these vibrations, and if possible - remove the source. If the vibrations cannot be prevented mount appropriate damping systems. If the chattering of the valve is due to incorrect valve selection (see "Vibration") - analyse the accuracy of the valve selection and if necessary replace it.
	Medium pollutions, foreign substances between the disc and seat	Shortly lift valve disc to remove any impurities, and if it does not bring the expected results – take off the valve and perform regeneration of the sealing surfaces of the seat and the disc or replace it with new one. If it is possible - apply valve with soft seal on the valve disc, which has a lower sensitivity to grit in the seat. Follow manufacturer's instructions.
	Corrosion of elements directly in contact with the medium, which is the result of improper valve selection in respect of material	Replace the valve with the construction appropriate to the medium according to resistance of used materials or apply safety valve system with a bursting disc
	The deformation caused by stresses of the installation. Valve bodies can get deformed due to excessive load transferred from the pipes, causing, among others, leaking.	Diagnose and eliminate the causes of stress. If the deformations of valve body are permanent- replace the safety valve with a new one.
	Other causes of leaks on the seat.	Depending on the reason diagnosed - according to the indications and decision of the manufacturer - replace the defective parts or replace the safety valve with a new one.
Safety valve opens at a pressure lower than at adjusted opening pressure	With the cold setting of a valve, appropriate temperature adjustment was not included. (in case of valves used for media of 100°C and higher)	Revise opening pressure, observing the guidelines and recommendations of the manufacturer.
	Slight damage or contamination of the sealing surface of the seat / disc	Remove the valve, check the sealing surfaces and, if necessary - make

		regeneration according to the manufacturer's instructions and recommendations.
	The valve is set to the differential pressure (considering the presence of superimposed backpressure) when the backpressure don't exist	Send valve to manufacturer to correct the set pressure
Sudden increases in pressure (pulsations)	Incorrect positioning of the safety valve at pressure source	Analyse mounting place of the safety valve at pressure source. Safety valve should be installed in such a distance from pressure source that protects it from the pressure pulsations.
Crack in the flange of safety valve body	Transport defect	Replace safety valve
	defect of the material	Replace safety valve
	Installation errors	Replace safety valve. Strictly follow manufacturer's instructions and the requirements of the relevant provisions in terms of requirements for installation of safety valves – do not induce stress during installation.
	Forces like bending, or torque act on safety valve.	Replace safety valve. When designing the installation check the manufacturer's instructions and the requirements of the relevant provisions of supervision institutions in the requirements for pipes connected to the safety valve, taking into account all the possible reaction forces occurring at the outlet, provide for appropriate support, do not let the valve to be a supporting structure for the other elements of the installation. Consider the possibility to use safety valves with support lugs.
Vibrations	Too high flow resistance in the supply line - pressure loss in the supply line exceeds 3% (set pressure of safety valve)	Reduce flow resistance in the supply line. If this is not possible, for some reasons - consider the possibility of a safety valve with damper. Effectiveness of this valve construction is possible in particular conditions – clarify with the manufacturer.
	Wrong characteristic of the safety valve in the protected installation	Analyse this matter, taking into consideration special conditions. If such adjustment is not possible- replace the valve with a new one with a proper characteristics.
	The valve was designed with too large capacity in relation to the requirements of protected installation.	Analyse the selection of safety valve – apply smaller valve, respectively to the required capacity.
	Built-up backpressure occurring in the discharge line at the blow out from the valve - exceeds the value allowed by the manufacturer (10 ÷ 15% of the set pressure) -e.g. too long outlet pipe, its diameter is too small, rapid changes in the direction of flow, the use of silencers, etc.	If it is not possible to introduce changes to the construction of discharge line, reducing built-up backpressure - apply valve with bellow compensation
	High fluctuation of backpressure	Apply valve with bellow compensation
	Too large construction lift of closing element	Apply safety valve of characteristics adjusted to this type of fluids, or- if the manufacturer enables such construction-

	(e.g. in case of full lift safety valves used for fluids)	reduce the construction lift of the full lift valve to the value indicated by the manufacturer.
	Incorrectly made welds on connecting pipes, too small gaskets on inlet and outlet or gaskets placed incorrectly (non-centrally) disrupting the flow	Eliminate incorrections
Pressure in installation still rising despite open safety valve.	Inadequate selection of the safety valve – too small capacity of the valve in relation to the installation requirements	Reselect the valve considering the required capacity and replace it with a proper one.
Safety valve constantly releases medium	“hangs” of the valve (the valve opened but did not close)	Diagnose the cause of the “hangs” If it is not possible to eliminate the reason- replace the valve.
	Very large damage to the surface of sealing, e.g. as the result of long-term leakage, crack of seat, “pitting” due to the medium	Replace the valve with a new one.
	Pressure do not fall down to closing pressure	Preserve adequate ratio between working and closing pressure
Crew injuries at discharge condition and external medium leakage	Use of safety valve without external tightness test confirmed by the manufacturer	Use valve with gastight construction, that is with external tightness test of the valve.
	Use of valve in which sealing is not adequate to the properties and parameters of medium.	Replace sealing in the operating valve with the adequate one (after consulting the manufacturer) or replace the whole valve.
	Incorrect discharge of medium from the safety valve	In case of steams and gases, the discharging pipe should be directed upwards, enabling safe discharge, minding that outlet end connector cannot be rigidly connected to the pipeline. In addition, in each case, the safety valve outlet flange (free discharge into the environment) or drain line must be positioned so that the flowing medium does not pose a threat to the environment. Follow the requirements of supervising institutions regulations and indications and recommendations of the manufacturer.
	Incorrect drainage medium form the valve and form the discharge pipe.	Eliminate the incorrectness in the drainage line, following the requirements of supervising institutions regulations and indications and recommendations of the manufacturer.
Condensate in the expansion chamber of the safety valve	Improper drainage installation - discharging fluid from the safety valve, improper drainage installation, clogged drainage system	Eliminate the incorrectness in the discharge and drainage installations. In the lowest point of discharge installation it is required to apply drainage guarantying effective discharge of residual condensate. If the manufacturer of the safety valve offers the version with drainage of the expansion chamber of valve body – it should also be considered to use such a valve.

<p>Noise emissions above the limit value (in case of discharge of steams and gasses)</p>	<p>Significant flow rates at medium discharge from the safety valve</p>	<p>In the case of minor exceedances of limit values - consider the possibility of reducing the flow speed through the use of larger safety valve. It should be checked, however, that "oversizing" of the valve did not cause the instability of its work (see "vibrations").</p> <p>In most cases it is necessary to apply silencer directly behind the valve and screening of the valve (noise barriers). While designing the outlet pipes fitted with silencers, static and dynamic interaction of flow stream flowing through the silencer should be taken into account. Silencer body should not interfere with effective operation of safety valve and additional pressure drops should be taken under consideration while calculating the discharge, and drainage pipes of the valve. In each case it should be considered not to exceed the value of backpressure allowed by the manufacturer of the safety valve.</p>
--	---	--

13. Valve service discontinuity

All obsolete and dismantled valves must not be disposed with household waste. ZETKAMA valves are made of materials which can be re-used and should be delivered to designated recycling centers.

14. Warranty

ZETKAMA grants quality warranty with assurance for proper operation of its products, providing that assembly of them is done according to the user's manual and they are operated according to technical conditions and parameters described in ZETKAMA's catalogue cards. Warranty period is 18 months starting from assembly date, however not longer than 24 months from the sales date.

Other warranty terms require agreement between the valve manufacturer and the buyer. The manufacturer reserves the right to introduce technical changes resulting from the improvement of design and manufacturing technology. Failure by the user to comply with the provisions and instructions contained in this manual releases the manufacturer from any obligations and warranties.

- The guarantee does not cover an assembly of third party spare parts and design changes made by the user, as well as changes in set pressure and natural wear and tear.
- The user should inform ZETKAMA about latent defects of the product immediately after they are found.
- The complaint must be made in writing.



The warranty is lost if the seal between the cap and the bonnet of the safety valve is broken.

Address for correspondence:

ZETKAMA Sp. z o.o.
ul. 3 Maja 12
57-410 Ścinawka Średnia

Phone +48 74 86 52 111

Fax +48 74 86 52 101

Website: www.zetkama.com