

USER MANUAL

**DIFREN PRESSURE
 REGULATING VALVE**

Fig. 223

Version: 1/2017
 Data: 01.01.2017

TABLE OF CONTENTS

1. Product description
2. Requirements for maintenance staff
3. Transport and storage
4. Function
5. Application
6. Installation
7. Operation
8. Maintenance and repair
9. Causes of operating disturbances and their elimination
10. Decommissioning
11. Terms of warranty



1. PRODUCT DESCRIPTION

figura 223
 ends threaded
 form Y-type

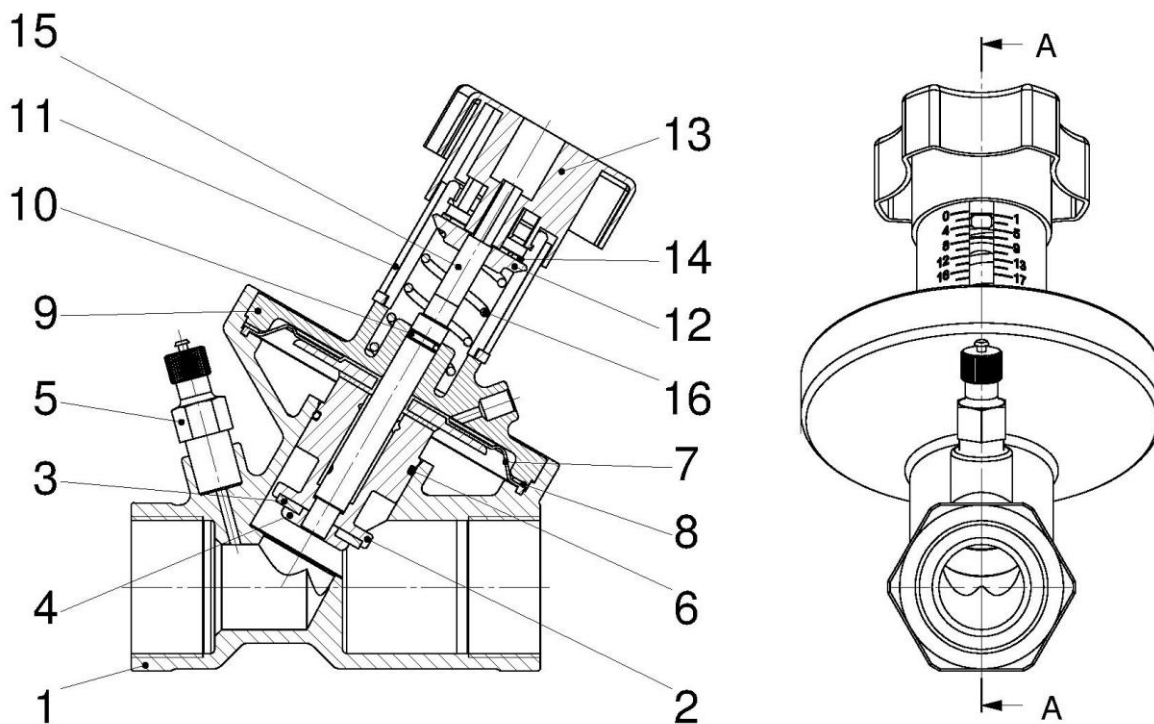

Drawing No. 1

Materials from which the valve is made contains tables 1.

Tables 1

body material		H
type		55,56,65,66
1	body	CuZn36Pb2As
2	disc	CuZn36Pb2As
3	seal of the disc	EPDM
4	retaining ring	CuZn36Pb2As
5	measuring nipples	CuZn36Pb2As
6	o-ring	EPDM
7	diaphragm	EPDM + X5CrNi18-10
8	support	SPETOBAR BAS 340
9	bonnet	CuZn36Pb2As
10	o-ring	EPDM
11	hand-wheel - scale	polyamide
12	nut spring	CuZn36Pb2As
13	hand-wheel	polyamide
14	retaining ring	A2
15	stem	CuZn36Pb2As
16	spring	X17CrNi16-2
max. temperature		120°

DPRV valve are made in the following ranges difference pressure:

$\Delta P_{\text{instal}} = 10 - 30 \text{ kPa}$ for DN 15-25

$\Delta P_{\text{instal}} = 25 - 70 \text{ kPa}$ for DN 15-25

$\Delta P_{\text{instal}} = 20 - 60 \text{ kPa}$ for DN 32-50

$\Delta P_{\text{instal}} = 40 - 90 \text{ kPa}$ for DN 32-50

$T_{\text{max}} : 120^{\circ}\text{C}$

$T_{\text{min}} : - 10^{\circ}\text{C}$

Valves produced by ZETKAMA, including DPRV, have a permanent marking compliant with the requirements of PN-EN19. The marking facilitates technical identification and contains:

- Nominal diameter DN (mm),
- Nominal pressure PN (bar),
- Designation of the material of which the body and cover are made,
- Arrow indicating the direction of flow,
- manufacturer,

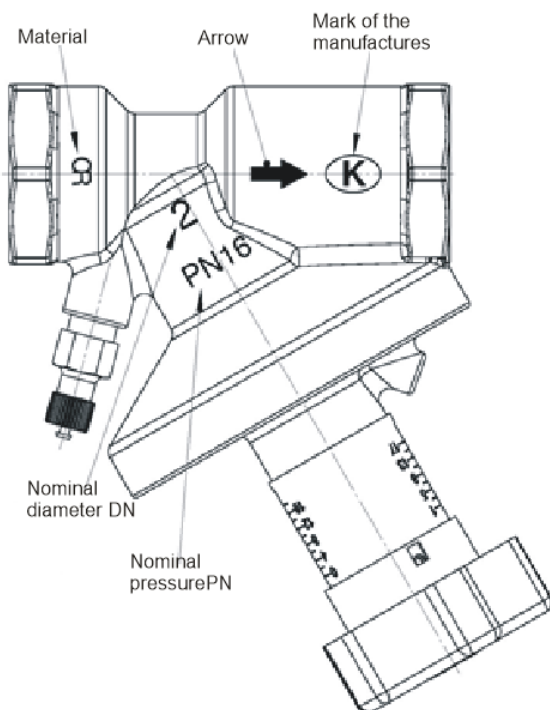

2. REQUIREMENTS FOR MAINTENANCE STAFF

The staff assigned to assembly, operating and maintenance shall be qualified to perform this work. During valve operation heat parts of the valve, e.g. body or cover parts could cause burn. If necessary the user should fit insulation shields and warning signs.

3. TRANSPORT AND STORAGE

Transport and storage should be carried out at a temperature from -20°C to 65°C , and valves should be protected against external forces. Valves must be stored free from contaminants and protected against the weather. In humid areas drying agent or heating should be applied to prevent the formation of condensation. The valves should be transported in a manner that does not damage the handwheel.

4. FUNCTION

Differential pressure controller maintains a constant differential pressure adjustable at a given flow. The regulation is accurate and stable so that there is less risk of noise from control valves.

Controls are mounted on pipes return.

It is possible to shutting off the flow by closing the regulator, using the dial item 13 - Turn the knob in the clockwise direction until closing.

5. APPLICATION

- heating
- refrigeration and air conditioning
- industrial water
- neutral fluids

Working medium requires or prohibits the use of certain materials. The valves are designed for normal conditions of use. In the case that working conditions exceed these requirements, e.g. in the case of aggressive or abrasive factors, a user should make an inquiry to the manufacturer before ordering.

Working pressure should be adjusted to the maximum temperature of the medium, as shown below.

DPRV Fig. 223

		Temperature[° C]
Material	PN	-10 do 120
CuZn36Pb2As	16	16 bar



The responsibility for correct selection of the valve is borne by designer.

6. INSTALATION

At the assembly of DPRV valves, observe the following rules:

- before an assembly evaluate if the valves were not damaged during transport or storage, and make sure that applied valves are suitable for working conditions and the media in the system,
- remove caps if the DPRV valves are provided with them
- check if the interior of valve is free of foreign matter,
- protect valves during e.g. welding, against splinters and used plastics against excessive temperature



Pipeline, on which valves are mounted, should be arranged and mounted so the valve body is not transmitting bending moment and is not extended.

- use compensators in order to reduce the impact of thermal expansion of pipeline
- install the valve so that flow direction comply with an arrow placed on the body.

- correct operation of the valve requires suitably long straight sections:
5 x DN up and 2 x DN downstream
- during pipeline painting valve parts made of plastic and scale of the valve must be protected,
- valves can be mounted in any position, recommend position of the valve is wheel down,
- before starting the installation, especially after repairs, the pipeline should be flushed through with the fully opened valve,
- installation of strainer before the valve increases certainty of its correct functioning
- connect impulse pipe (pos. 1) between a balancing valve in the supply (item 2) and the feed opening of the diaphragm regulator (item 3) mounted on the return
- vent the upper and lower part and impulse pipe by loosening (item. 3) until water flows
- make a test the DPRV valve with cold water

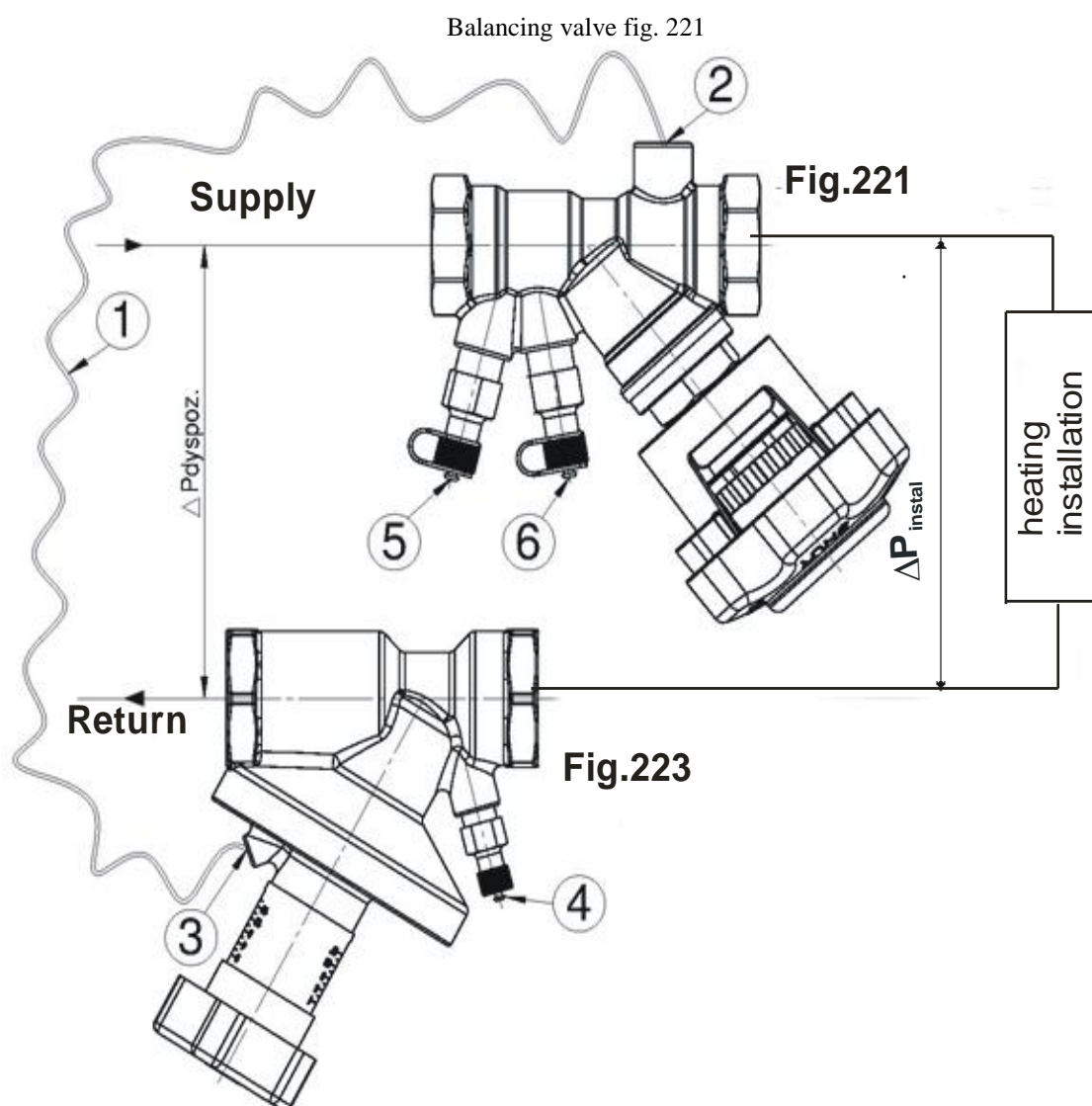

7. CONTROL AND SETTING

Setting the DPRV with the presetting valves :

1. Fully open all balancing valves
2. Set all valves at the end receivers on the design flow.
3. Set the differential pressure using of hand-wheel - number of rotations is given in Table 2.
4. Measure the pressure difference Δp_{instal} - using the Balancing Measuring Device T550, connecting it to the measuring nipples in Fig.221, item. 2, and the measuring nipples item. 4 of DPRV.
5. If the flow rate on a balancing valve Fig.221 is different from the design value, reset ΔP_{instal} to get on the valve in Fig.221 design value of flow rate.

Because the installation has of the inertia, wait a few minutes to read the measured values.

ΔP_{instal} [kPa]	Turn of hand wheel for DN 15-25		Turn of hand wheel for DN 32-50	
	10-30 kPa	25-70 kPa	20-60 kPa	40-90 kPa
10	0,0			
15	3,0			
20	6,0		0,0	
25	9,0	0,0	1,3	
30	12,0	1,3	2,5	
35		2,7	3,8	
40		4,0	5,0	0,0
45		5,3	6,3	1,0
50		6,7	7,5	2,0
55		8,0	8,8	3,0
60		9,3	10,0	4,0
65		10,7		5,0
70		12,0		6,0
75				7,0
80				8,0
85				9,0
90				10,0

 to ensure the safe operation of each valve and the regulator should be checked regularly.

8. MAINTENANCE AND REPAIR

DPRV valves Fig.223 do not require any maintenance provided that they are used in accordance with their intended use

 Before taking up any maintenance actions, make sure that you have cut off the flow of medium in the pipe, the pressure was reduced to ambient pressure, medium was removed and the system was cooled down.

- all maintenance and repair work should be performed by qualified personnel using suitable tools and original spare parts.
- during the maintenance and repair work personal protection measures appropriate for the risk involved should be used,
- after removing the valve there is a need to replace the sealing, with which the valve is connected to the pipeline,
- each time when the cover is removed, clean the valve sealing surface and apply new gasket of the same type as previously used
- tightening the cover to the body must be made with the valve opened (plug in the upper position)
- before reassembling the valve in the pipeline it is necessary to check valve operation and tightness of all connections. Tightness test should be carried out with water pressure of 1,5 x nominal pressure of the valve

9. CAUSES OF OPERATING DISTURBANCES AND THEIR ELIMINATION

- When searching for the malfunctioning of the valve safety rules must be observed

DISTURBANCE	POSSIBLE CAUSE	HOW TO REMOVE
No flow	Valve closed	Open the valve
	The caps not remove	Remove the caps
Low flow	Valve not sufficiently open	Open the valve
	Contaminated filter	Clean or replace the strainer
	Clogged pipeline system	Check the pipeline
Leakage on the spindle	Contaminated O-rings	Replace the O-rings
Leakage on the seat	Demaged the seat or plugs ring	Replace the valve.Contact the supplier or manufacturer
	Medium contaminated with solid objects	Clean the valve. Install the filter before the valve

10. DECOMMISSIONING

After decommissioning and dismantling, valves must not be disposed of with household waste. The valves are made of materials that can be recycled. To do this, deliver them to a recycling point.

11. Terms of warranty

ZETKAMA guarantees the quality with assurance for proper operation of its products, when installed in accordance with the instruction manual and the operation according to technical conditions and parameters described in the data sheets of ZETKAMA. The warranty period is 18 months from the date of installation, but not longer than 24 months from the date of sale.

The warranty does not cover assembly of foreign parts and design changes made by the user as well as natural wear. You should inform ZETKAMA about hidden defects of the product immediately after detection.

Complaint must be in writing.

Address for correspondence

ZETKAMA Sp. z o.o.
ul. 3 Maja 12
57-410 Ścinawka Średnia

Telefon +48 74 86 52 100
Telefax +48 74 86 52 101
Internet: www.zetkama.pl